

Safety Cut-Off Valve SERIES 305

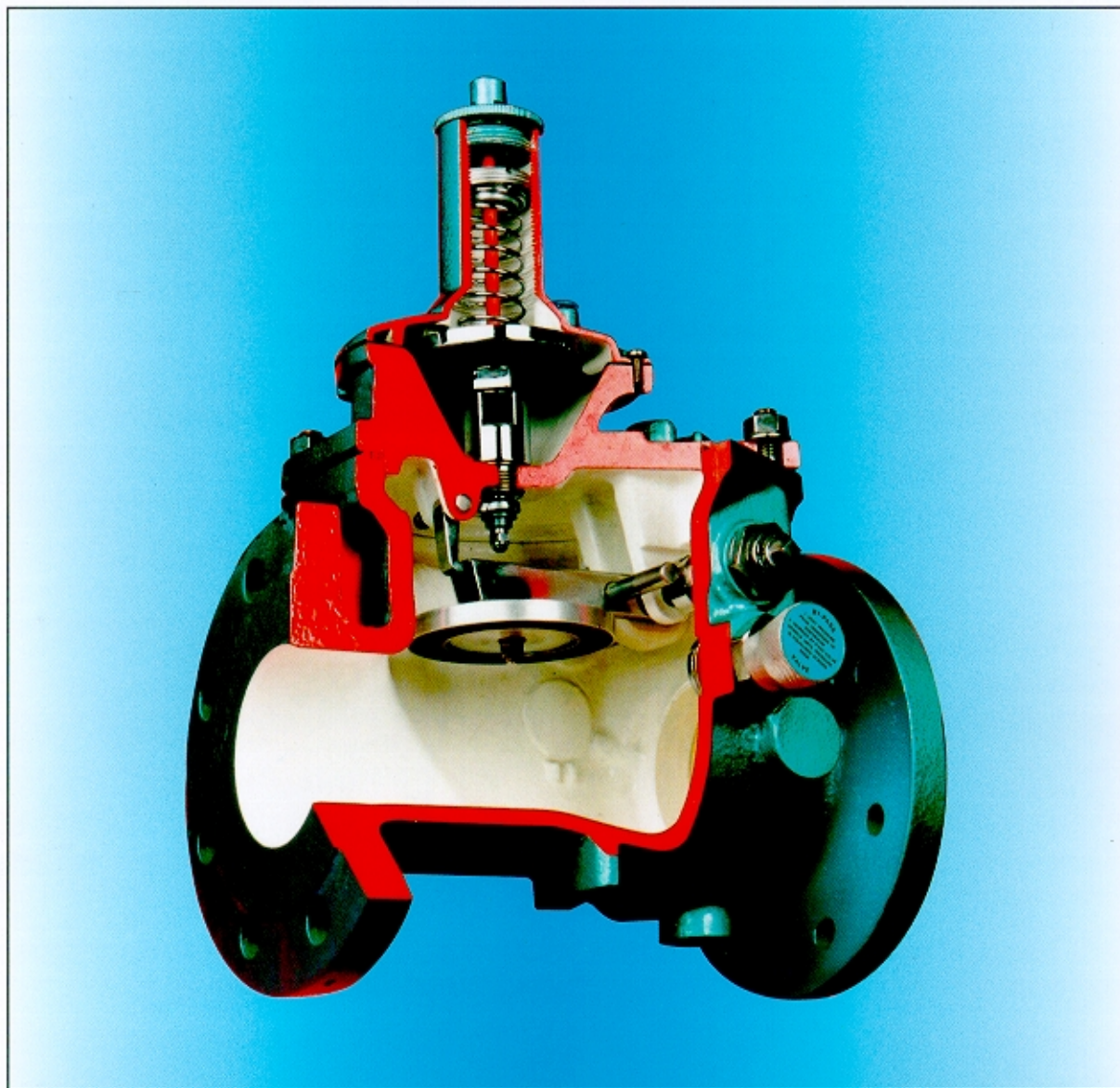

Technical Data



SS.305.00.998

Technical Data

Introduction

The Series 305 is a safety cut-off valve of single in line orifice design, overpressure operated, with external control line connection, manual reset and pressure balancing bypass. Completely self-acting and requires no separate power source to close the valve.

Application

Designed to safeguard gas distribution systems, normally installed upstream of the pressure regulator with the external control line piped to the downstream of the regulator, closing automatically in the event of an overpressure condition. After closure, the valve must be manually reset to the open position after normal pressure conditions have been restored by use of the manual bypass valve.

Features

- ❑ Helical torsion spring secures valve door in closed position.
- ❑ Fully enclosed valve position indicator – colour coded to show valve status.
- ❑ Specially designed spindle and seal between trigger mechanism and diaphragm actuator practically eliminates effect of inlet pressure variation on trip set point.
- ❑ Integral push button pressure equalising valve.
- ❑ Low Pressure Loss.
- ❑ Manual Reset.
- ❑ BG/PS/V9 approval.

Installation

Sizes up to and including 100mm can be installed in both the horizontal and vertical positions.

The 150mm and 200mm sized units can only be installed in the horizontal position with the spring housing pointing vertically upwards.

Options

Can be supplied with proximity sensor system to initiate 'valve-open' or 'valve-closed' indicator on remote panel.

Selection Guide

- ❑ **Series 305-LP**
Cast Iron or Ductile Iron Body and Casings
Low Pressure Spring housing
Range: 0.025 to 0.75 bar g (0.4 to 11 psig)
- ❑ **Series 305-MP**
Cast Iron or Ductile Iron Body and Casings
Low Pressure Spring housing with reducing plate.
Range: 0.3 to 2.75 bar g (4 to 40 psig)
- ❑ **Series 305-IP**
Cast Iron or Ductile Iron Body and Casings
Intermediate Pressure Spring housing.
Range: 2.5 to 6.0 bar g (36 to 87 psig)

Pressure Rating

- 10 barg (145 psig) - Cast Iron body and Top Cover
- 16 barg (232 psig) - Ductile Iron Body and Top Cover

Size Range

2" Screwed

- *50mm (2") Flanged
- 80mm (3") Flanged
- 100mm (4") Flanged
- 150mm (6") Flanged
- 200mm (8") Flanged

*50mm (2") - Flanged short face to face (SFF) model available on request

Temperature Range

-20°C to +60°C

Connections

Screwed connections: BS21 Rc, Rp and NPT (U.S.A.)

Flanged connections to BS.4504 PN16
(may be drilled to other standards on request)

External Control Line connection: Rc 1/4 (1/4" NPT - U.S.A.)

Diaphragm breather connection: Rc 1/8 (1/8" NPT - U.S.A.)

Spring Selection

Model	Spring		Trip Pressure Range			
	Number	Colour	Minimum bar g	Maximum bar g	Minimum psi g	Maximum psi g
305-LP Low Pressure	*1200	Silver	0.025	0.05	0.4	0.7
	495	Orange	0.045	0.125	0.6	1.8
	835	Blue	0.112	0.25	1.6	3.6
	839	Grey	0.235	0.35	3.4	5.0
	1054	Red/White	0.28	0.55	4.0	8.0
	1059	Red/Yellow	0.5	0.75	7.0	11.0
305-MP Medium Pressure	495	Orange	0.3	0.4	4.0	6.0
	835	Blue	0.36	0.9	5.0	13.0
	839	Grey	0.8	1.35	11.5	20.0
	1054	Red/White	1.12	2.25	16.0	32.5
	1059	Red/Yellow	1.95	2.75	28.0	40.0
	305-IP Intermediate Pressure	1077	Yellow	2.5	3.3	36.0
1078		Green	3.1	4.0	45.0	58.0
1079		White	3.8	5.0	55.0	72.0
1080		Red	4.8	6.0	70.0	87.0

* Non BG/PS/V9 Spring Range

Pressure Loss

The Series 305 is designed for minimal pressure loss (Δp)

$$P_i - P_o = \frac{P_i - \sqrt{P_i^2 - 4(Q/K)^2}}{2} \text{ bar}$$

Where:

Q = Valve flow M³/Hr (SG 0.6)

P_i = Inlet pressure bar (abs)

P_o = Outlet Pressure bar (abs)

K = Flow Constant

(abs) = Absolute pressure 1.01325

When sizing valves in accordance with PS/V9, the maximum recommended gas velocity through the safety cut-off valve should not exceed 80 m/sec, (262 ft./sec).

Consideration given to higher gas velocities on request – please contact BD-RMG for details.

Flow Constant

Valve Size	Flow Constant
2" & 50mm	3860
80mm	7861
100mm	16302
150mm	49780
200mm	78818

Conversion Factors

The pressure loss calculation is given in terms of natural gas SG 0.6. For all other gases multiply by the following correction factor:

$$\sqrt{\frac{0.6}{\text{SG of other gas}}}$$

Conversion to ft³/hr - multiply by 35.3

Dimensions & Materials of Construction

Dimensions & Weights

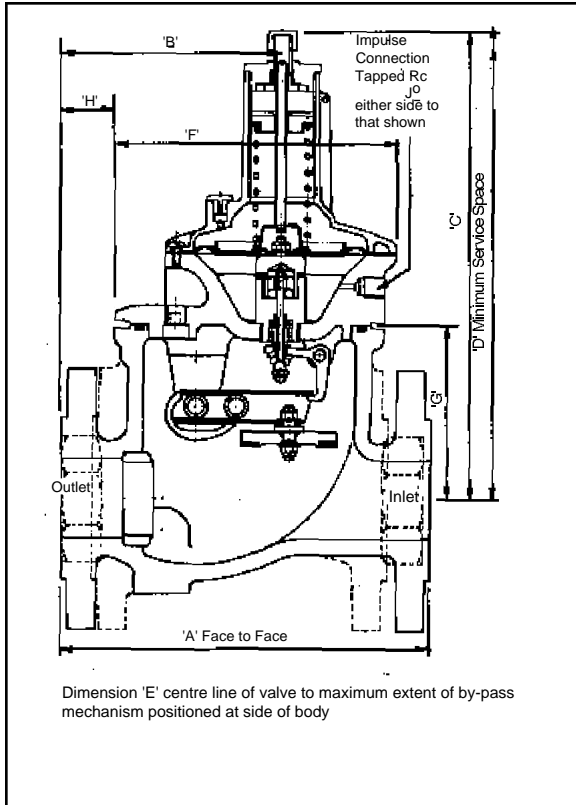

Materials of Construction

Component	Material
Body and top cover	Cast Iron: BS.1452 Grade 220 or Ductile Iron: BS.2789 Grade 420:12 alt 400/18L20
Spring housing and cap (Dependent on model)	Aluminium - BS.1490 Grade LM24 Cast Iron - BS.1452 Grade 220 Ductile Iron - BS.2789 Grade - 420:12
Ball, Trigger assembly and operating spindles	Stainless Steel: BS.970 Grade 416S21
Valve Orifice	Stainless Steel: BS.970 Grade 316S21
Seal retainer, reset and bypass housing	Brass: BS.2874 Grade CZ 121
Diaphragm	Nylon reinforced nitrile
Diaphragm plate	Mild Steel: BS.1449 Grade D1 zinc plated
'O' Rings	Nitrile
Main spring	Spring Steel: BS.1726 oiled finish
Bypass spring, door spring and trigger spring	Stainless Steel: BS.970 Grade 302S25
Reset spring	Music Wire: BS.5216 Grade M5
Valve door	Aluminium: BS.1474 Grade HE 30 TF with polyurethane seat 70/75 shore hardness

Size	Connections	Dimensions (mm)								Degrees J	Weight Kg
		A	B	C	D	E	F	G	H		
2"	Screwed	225	136	295	400	125	168	110	33	-	16
50mm	Flanged	230	136	295	400	125	168	110	33	-	21
50mm	Flanged (S.F.F.)	184	116	295	400	125	168	110	13	-	18
80mm	Flanged	276	169	310	430	135	208	126	38	-	29
100mm	Flanged	292	169	320	455	135	208	137	38	-	33
150mm	Flanged	381	203	370	505	206	273	178	67	30	75
200mm	Flanged	457	248	405	540	234	330	216	83	40	108

Sectional Arrangement

Key:

	LINE PRESSURE
	IMPULSE PRESSURE
	ATMOSPHERIC PRESSURE

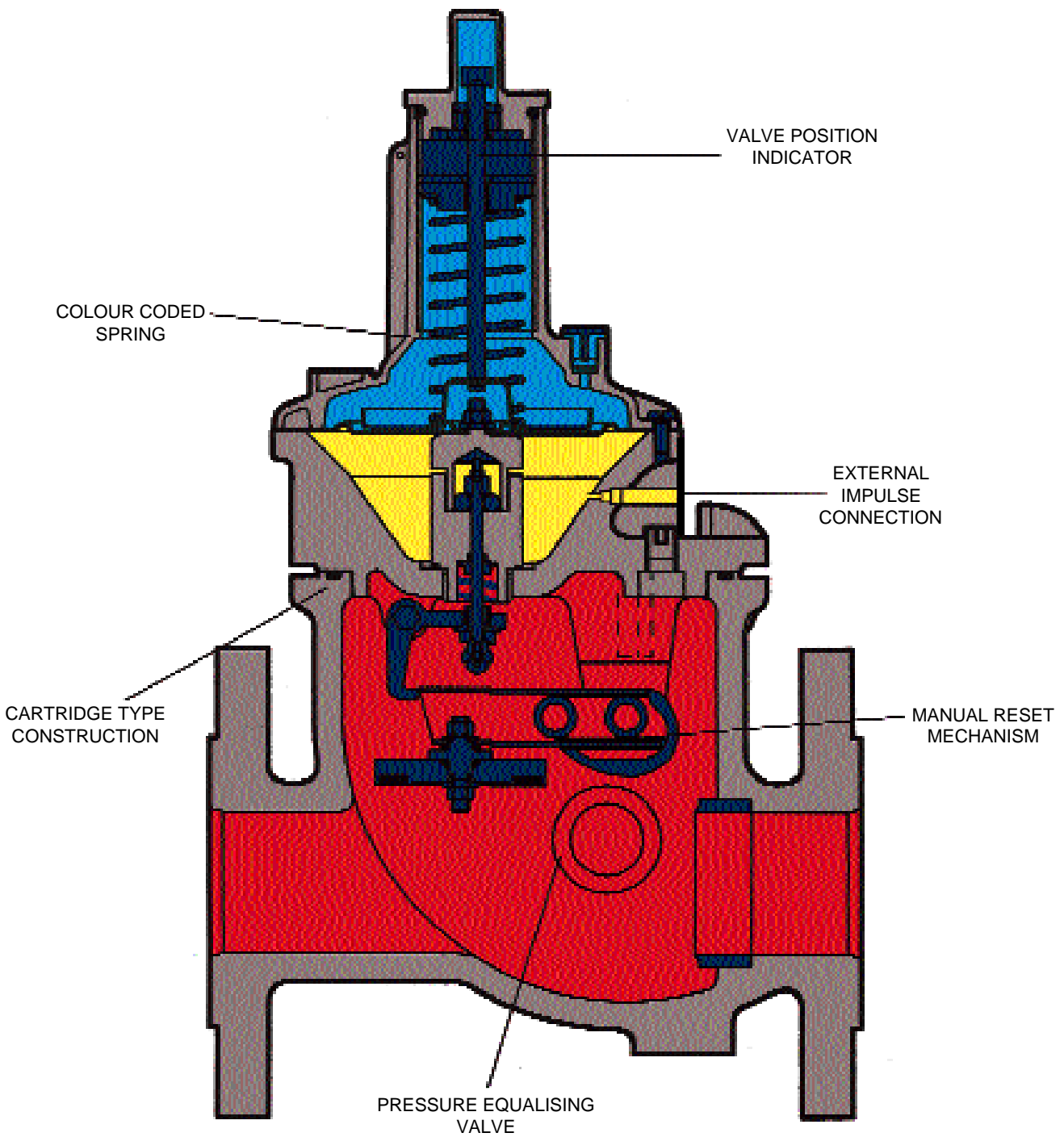

The RMG Group of Companies



RMG REGEL + MESSTECHNIK GMBH

Osterholzstrasse 45, D-34123 Kassel, Germany
Telephone (+49) 561 5007-0 • Fax (+49) 561 5007-107
gas pressure regulators and safety devices



Bryan Donkin RMG Gas Controls Limited

Enterprise Drive, Holmewood, Chesterfield S42 5UZ, England
Telephone ++44 (0)1246 501501 • Fax ++44 (0)1246 501500
gas pressure regulators, safety devices, electronic control systems,
design and assembly of gas pressure regulating and metering stations



Bryan Donkin RMG Canada Limited

P.O. Box. 427, 50 Clark Street South, Woodstock, Ontario, Canada. N4S 7Y5
Telephone (+1) 519 539 8531 • Fax (+1) 519 537 3339
gas pressure regulators and safety devices



RMG Messtechnik GmbH

Otto-Hahn-Strasse 5, D-35510 Butzbach, Germany
Telephone (+49) 6033 897-10 • Fax (+49) 6033 897-130
turbine meters, vortex meters and electronic corrector systems, odourizing equipment



RMG electronic GmbH

Heinrich-Lanz-Strasse 9, D-67259 Beindersheim/Pfalz, Germany
Telephone (+49) 6233 3762-0 • Fax (+49) 6233 3762-40
hardware and software according to customers' specifications



Karl Wieser GmbH

Anzinger Straße 14, D-85560 Ebersberg, Germany
Telephone (+49) 8092 2097-0 • Fax (+49) 8092 2097-10
tariff recorders, danger alarm systems and monitor systems



WÄGA Wärme-Gastechnik GmbH

Osterholzstrasse 45, D-34123 Kassel, Germany
Telephone (+49) 561 5007-0 • Fax (+49) 561 5007-207
design and assembly of gas pressure regulating and metering stations



RMG-GASELAN Regel + Meßtechnik GmbH

Julius-Pintsch-Ring 3, D-15517 Fürstenwalde, Germany
Telephone (+49) 3361 356-600 • Fax (+49) 3361 356-836
gas pressure regulators and safety devices, rotary displacement meters,
design and assembly of gas pressure regulating and metering stations



Serving the Gas Industry Worldwide

Bryan Donkin RMG Gas Controls Limited

Enterprise Drive, Holmewood, Chesterfield S42 5UZ, England
Tel: ++44 (0)1246 501501 Fax: ++44 (0)1246 501500
Direct Sales Line: ++44 (0)1246 501555

